

Fieldbus Appendix

AnyBus-S Drive Profile Profibus DPV1

Rev. 2.01

HMS Industrial Networks AB

Germany +49- 721 - 96472 - 0
Japan +81- 45 - 478 -5340
Sweden +46- 35 - 17 29 20
U.S.A +1- 773 - 404 - 2271

sales-ge@hms-networks.com
sales-jp@hms-networks.com
sales@hms-networks.com
sales-us@hms-networks.com



Table of Contents

Preface	About This Manual	
	How To Use This Manual	P-1
	Important User Information	P-1
	Related Documentation	P-1
	Revision List.....	P-1
	Conventions Used in This Manual	P-2
	Support	P-2
Chapter 1	About the AnyBus-S Drive Profile Profibus DPV1	
	Features.....	1-1
	Compatible Products	1-1
	GSD-file.....	1-1
	Overview	1-2
	Application Connector.....	1-2
	Profibus Connector.....	1-2
	Termination Switch.....	1-2
	Status Indicators	1-3
	Node Address Switches.....	1-3
Chapter 2	Profibus Slave Interface	
	PPO Configuration	2-1
	User Parameter Data.....	2-2
	<i>Parameter Data Telegram</i>	2-2
	<i>Extended User Parameter Data</i>	2-2
	Diagnostics	2-4
	<i>Standard Diagnostics</i>	2-4
	<i>Communication Diagnostics</i>	2-4
	Configuration of PZD words.....	2-5
Chapter 3	Operating the Inverter via the PROFIdrive Profile	
	General.....	3-1
	PPO Description.....	3-1
	PKW-Part.....	3-2
	<i>PKE (PKW word 1) Explanation</i>	3-2
	PZD-Part.....	3-3
	<i>Profile Mode and Vendor Specific Mode</i>	3-4
	<i>PROFIdrive State Machine</i>	3-6
	<i>Set-point/ Actual value</i>	3-7
	Acyclic Parameter Channel (DPV1)	3-8
	<i>DPV1 Request Header Structure</i>	3-8
	<i>DPV1 Response Header Structure</i>	3-8

	<i>DPV1 Request/Response Header Explanation</i>	3-9
	<i>DPV1 Parameter Request Error Codes</i>	3-10
Chapter 4	Parameters	
	PROFIdrive Profile Specific Parameters	4-1
	<i>Description Elements</i>	4-3
	<i>Fault Buffer Explanation</i>	4-5
	Bus Config Parameters	4-6
Chapter 5	Configuration with the ABSDP Development Tool	
	PROFIdrive Specific Configuration	5-1
	<i>Changing Profibus Ident Number</i>	5-1
	Parameter Data Mapping	5-2
	<i>User Specific Mapping Example</i>	5-3
	Profibus GSD file Generator	5-4
Appendix A	Connector Pinouts	
	Application Connector	A-1
	Fieldbus Connector	A-1
Appendix B	Mechanical Specification	
	<i>Angled Switches & Connectors (Standard)</i>	B-1
	<i>Straight Switches & Connectors</i>	B-2
Appendix C	Electrical Characteristics	
	Supply Voltage	C-1
	Power Consumption	C-1
	PE Grounding	C-1
Appendix D	Environmental Specification	
	Temperature	D-1
	Relative Humidity	D-1
	EMC compliance	D-1

About This Manual

How To Use This Manual

This fieldbus appendix contains fieldbus specific information about Profibus and PROFIdrive for the AnyBus-S Drive Profile Profibus DPV1. For more information about the AnyBus-S Drive Profile platform, consult the AnyBus-S Drive Profile Design Guide.

Important User Information

The data and illustrations found in this document are not binding. We, HMS Industrial Networks AB, reserve the right to modify our products in line with our policy of continuous product development. The information in this document is subject to change without notice and should not be considered as a commitment by HMS Industrial Networks AB. HMS Industrial Networks AB assumes no responsibility for any errors that may appear in this document.

There are many applications of this product. Those responsible for the use of this device must ensure that all the necessary steps have been taken to verify that the application meets all performance and safety requirements including any applicable laws, regulations, codes, and standards.

AnyBus® is a registered trademark of HMS Industrial Networks AB. All other trademarks are the property of their respective holders.

Related Documentation

Document name	Author
AnyBus-S Drive Profile Design Guide	HMS Industrial Networks AB
AnyBus-S Design Guide	HMS Industrial Networks AB
DRIVECOM - Drive Engineering / Servo Profile	-
PROFIBUS Profile for variable speed drives, PROFIdrive	PNO
PROFIdrive - Profile Drive Technology Version 3 September 2000	PNO

Revision List

Revision	Date	Author	Chapter	Description
2.00	2003-10-08	HMS	All	Created
2.01	2003-12-18	HMS	4	BUS_CFG_20 - corrected name and settings

Conventions Used in This Manual

The following conventions are used throughout this manual:

- Numbered lists provide sequential steps
- Bulleted lists provide information, not procedural steps
- The term ‘module’ is used when referring to the AnyBus module
- The term ‘application’ is used when referring to the hardware that is connected to the AnyBus Application Connector
- Hexadecimal values are written in the format NNNNh, where NNNN is the hexadecimal value.

Support

Europe (Sweden)

E-mail: support@hms-networks.com
Phone: +46 (0) 35 - 17 29 20
Fax: +46 (0) 35 - 17 29 09
Online: www.hms-networks.com

HMS America

E-mail: us-support@hms-networks.com
Phone: +1-773-404-2271
Toll Free: 888-8-AnyBus
Fax: +1-773-404-1797
Online: www.hms-networks.com

HMS Germany

E-mail: ge-support@hms-networks.com
Phone: +49-721-96472-0
Fax: +49-721-964-7210
Online: www.hms-networks.com

HMS Japan

E-mail: jp-support@hms-networks.com
Phone: +81-45-478-5340
Fax: +81-45-476-0315
Online: www.hms-networks.com

About the AnyBus-S Drive Profile Profibus DPV1

The AnyBus-S Drive Profile Profibus DPV1 is a Profibus slave communication module that can be read and written to, from a Profibus master.

The module is tailor made for use in drive applications. In addition to the standard Profibus-DP services, a complete PROFIdrive Profile server is included in the on-board firmware. The PROFIdrive profile server can be easily adapted to the functionality of the drive by using the HMS Drive Profile Development Tool. The interface transmits up to 65 k Byte of parameter data to/from the drive. The module supports the parallel Dual Port Ram interface as well as the serial Rx/Tx Host interface. An acyclic parameter channel is also available using the DPV1 services. This parameter channel is implemented according to the PROFIdrive V3 specification.

Features

- Supports all mandatory Profibus-DP/DPV1 Slave functions + Sync, Freeze and Clear mode
- Support for PROFIdrive V2 parameter channel PKW based on I/O-data
- Support for PROFIdrive V3 parameter channel based on DPV1 acyclic data
- Configurable PROFIdrive Profile Server included in on-board firmware
- Supports standard PPO1 – PPO5 with 4 – 28 Byte I/O data
- Drive Profile configuration tool available free of charge
- GSD-file is automatically generated by ABSDP Development Tool
- Configurable Failsafe behaviour
- Supports up to 65 k Bytes of drive parameter data
- Onboard baudrate and bus termination switches
- Galvanically isolated bus electronics

Compatible Products

This product is a member of the AnyBus concept of interchangeable fieldbus modules. This makes it fully interchangeable with any fieldbus system supported by the AnyBus-S Drive Profile platform.

GSD-file

Each device on a Profibus network is associated with a GSD file, containing all necessary information about the device. This file is used by the network configuration program during configuration of the network.

The module is configurable for DPV0 and DPV1 mode by the end user. This selection is made using the bus config parameters, see 4-6 “Bus Config Parameters” (BUS_CFG_20 ‘DPV1 Mode’).

The ABSDP Development Tool contains a GSD file generator used to automatically create a Profibus GSD file based on the configuration. In the GSD file generator, it is also possible to select whether the target application should use DPV0 or DPV1.

Overview

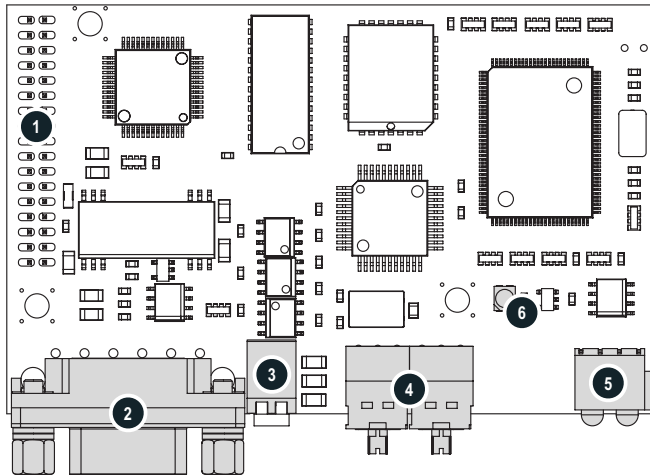

#	Description
1	Application Connector ^a
2	Profibus Connector
3	Termination Switch
4	Node Address Switches
5	Status Indicators
6	AnyBus Watchdog Led ^a

a. Consult the general AnyBus-S Drive Profile Design Guide for more information

Application Connector

This connector features a standard AnyBus-S Drive Profile application interface. Consult the general AnyBus-S Drive Profile Design Guide for further information.

Profibus Connector

The connector features a galvanically isolated Profibus interface. The standard connector is a 9 pin female DSUB. Other connector designs are also possible. For more information about connectors and pin assignments, see Appendix B-1 “Connector Pinouts”

Termination Switch

The end nodes in a Profibus network segment must be properly terminated in order to avoid reflections on the bus lines. For this purpose, the module features an on board termination switch. If the modules is the first or last physical node on a segment, the termination switch should be set to ON.

- **Termination switch ON**
Bus termination enabled.
- **Termination switch OFF**
Bus termination disabled. (Use this setting when using external termination.)

Status Indicators



These leds indicate run time status and errors to the user.

#	Indication	State	Description
1	Host communication status	Off	Module not initialised
		Green	Communication running
		Red	Communication lost, permanently
		Red, Flashing 1Hz	Communication lost, temporary
2	On Line	Off	Module is not on line, or no power
		Green	Module is on line and data exchange is possible. (Fieldbus running bit set in AnyBus status register)
		Green, Flashing 1Hz	“Fail safe mode” (PLC not active bit set in Anybus Status register)
3	Off Line	Off	Module is not off line, or no power
		Red	Bus is off line (Fieldbus running bit set in AnyBus status register)
		Red, Flashing 1Hz	Bus is off line, but is waiting for cut-off timeout
4	Fieldbus Diagnostics	Off	No diagnostics present, or no power
		Red, Flashing 1Hz	Error in configuration data (Fieldbus Config Error bit set in AnyBus Status register)
		Red, Flashing 2Hz	Error in parameter data (Fieldbus Config Error bit set in AnyBus Status register)
		Red, Flashing 4Hz	Profibus ASIC initialisation error (Fieldbus ASIC Error bit set in AnyBus Status register)

Node Address Switches

Before power-on the Profibus node address has to be set. This can be done in two ways; either via the two onboard rotary switches, or by letting the module read the node address from the BUS_CONFIG_1 parameter in the inverter. The latter is used when no rotary switches are present, or if the switches are set to zero.

Note: The switches are read once during startup, i.e. any changes requires a reset.

Switches	Node Address
Not present	Determined by 'BUS_CONFIG_1' parameter
0	
1 - 99	Node address set by rotary switches. See example below. (BUS_CONFIG_1 reflects actual value)

Example:

Address = (Left Switch Setting x 10) + (Right Switch Setting x 1)

In this example, the actual node address will be 42 (4 x 10 + 2 x 1)

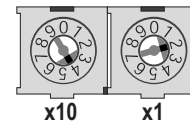

Profibus Slave Interface

PPO Configuration

The module starts up with PPO Type 1 as default, however when the master initiates communication with the slave it sends a Chk_Cfg telegram (SAP62) containing a string of octets with the configuration the user has selected with the Profibus configuration tool (e.g. AnyBus NetTool for Profibus).

The slave compares the new configuration with the actual configuration, and if the configuration differs it updates its configuration (if the configuration data is valid). The master also has the opportunity to read the current configuration of the module using a "Read Configuration" telegram (SAP59).

The module supports all five PPOs specified in the PROFIdrive drive profile plus one additional PPO (PPO6), see table below.

PPO	Identifier(s)	PROFIdrive Parameter Enabled	PZD Size	PKW Size
PPO1	F3h, F1h	Acyclic Parameter Read	4	8
PPO2	F3h, F5h	Acyclic Parameter Read	12	8
PPO3	F1h	Acyclic Parameter Read/Write	4	0
PPO4	F5h	Acyclic Parameter Read/Write	12	0
PPO5	F3h, F7h	Acyclic Parameter Read	20	8
PPO6	F9h	Acyclic Parameter Read/Write	20	0

By selecting PPO3, 4 or 6 acyclic parameter write is enabled. In PPO1, 2 and 5 only acyclic parameter read requests are available. This means that with PPO1, 2 and 5 it is only possible to read parameter values with the acyclic interface, not write.

Note: The PPO-type can be changed during run-time, however the module will go off-line while the configuration is being updated.

User Parameter Data

When the master starts to communicate with the module it sends a Parameter Data (SAP61) telegram to it. The master uses this telegram to identify itself with the AnyBus module and to specify how the module should operate. This telegram contains a string of octets (bytes), 10 bytes of required parameter data, and 22 bytes of Extended User Parameter Data.

Some features of the bus interface are configured when the master is configured; these parameters are sent to the module using a "set extended user parameter data" telegram.

Parameter Data Telegram

Octet (DPV0)	Octet (DPV1)	Contents	Value
0	0	Station status (see DIN 19245-3)	-
1	1	Watchdog-Factor 1	1 - 255
2	2	Watchdog-Factor 2	1 - 255
3	3	Minimum station delay (Min TSDR)	0 - 255
4	4	Vendor ID (High byte)	18h
5	5	Vendor ID (Low byte)	02h
6	6	Group identity (see DIN 19245-3)	-
7	7	DPV1 Status 1 (Reserved in DPV0)	-
-	8	DPV1 Status 2	-
-	9	DPV1 Status 3	-
8 - 30	10 - 32	Extended User Parameter Data	-

Extended User Parameter Data

Octet (DPV0)	Octet (DPV1)	Contents	Description	Value
8	10	Header byte	See 2-3 "Header Byte"	-
9-10	11-12	Cut-off timeout	The time to wait before clearing the FBonline bit in the AnyBus status to the inverter when the communication with the master is lost.	1 - 65536 ms 0: Do not clear AnyBus Status
11-12	13-14	Fail-safe, PZD1 (STW)	If fail-safe mode is selected to "USE FAIL-SAFE", this fail-safe value is sent to the module if this PZD is used.	0 - 65536
13-14	15-16	Fail-safe, PZD2 (HSW)		0 - 65536
15-16	17 - 18	Fail-safe, PZD3		0 - 65536
17 - 18	19 - 20	Fail-safe, PZD4		0 - 65536
19 - 20	21 - 22	Fail-safe, PZD5		0 - 65536
21 - 22	23 - 24	Fail-safe, PZD6		0 - 65536
23 - 24	25 - 26	Fail-safe, PZD7		0 - 65536
25 - 26	27 - 28	Fail-safe, PZD8		0 - 65536
27 - 28	29 - 30	Fail-safe, PZD9		0 - 65536
29 - 30	31 - 32	Fail-safe, PZD10		0 - 65536

Header Byte

Octet	Contents	Description	Range	Default
0 - 1	Fail-safe mode	Defines the action that will be taken if the PLC is switched from "RUN" to "STOP" mode.	0:STOP 1:LAST SPEED 2:USE FAIL-SAFE	STOP
2 - 3	Control zero mode ^a	Defines the action that will be taken if a Profibus telegram containing only zeroes is received.	0:USE FRAME 1:IGNORE	USE FRAME
4 - 5	Operation mode	Determines what control/status word and reference/actual values to use	0:PROFIDRIVE 1:VENDOR SPECIFIC ^b	PROFIDRIVE
6 - 7	(reserved)	-	-	-

a. With the "USE FRAME" setting selected the inverter might not be stopped (if it is running) since also bit 10 (Control by automation/No control) in the control word is zero. However, the other PZD's might still be updated, thus causing parameters to be written with zeroes.

b. When "Operation mode" is set to "VENDOR SPECIFIC", "Fail-safe mode" "STOP (0)" is the same as "LAST SPEED"

Diagnostics

Standard Diagnostics

The standard diagnostic in Profibus contains six octets of diagnostic information. The module features two additional octets of Extended Diagnostics; a header byte and a byte for communication diagnostic.

Octet (DPV0)	Octet (DPV1)	Designation	Notes
0	0	StationStatus_1	Standard diagnostics
1	1	StationStatus_2	
2	2	StationStatus_3	
3	3	Diag.Master_Add	
4	4	Ident_Number_High	
5	5	Ident_Number_Low	
6	6	Header Byte (Always 02h)	Extended diagnostics
-	7	StatusType = Status Message (81h)	
-	8	Slot_Number (00h)	
-	9	Specifier (00h)	
7	10	Communication Diagnostics (See below)	

Communication Diagnostics

The module supports one byte device related diagnostics. The purpose with the diagnostic is to give the user/PLC the ability to read the status of the communication between the module and the application.

The format of the diagnostic byte is described below:

Bit		Indication
0	Set	Communication temporary lost
	Cleared	-
1	Set	Communication permanently lost
	Cleared	-
2 - 7	-	(reserved)

Configuration of PZD words

Six different PPO-types are supported, PPO1/2/3/4/5 and 6. PPO2, 4, 5 and 6 supports cyclic update of up to ten parameters read and write. It is important to note that it is the actual parameter number of the inverter that shall be assigned, not the parameter number that is visible on the fieldbus.

Note: Available PZD words depends on the PPO configuration, see 2-1 “Process Data Objects (PPO)”.

Assignments in PZD Write (PLC to Inverter)

Parameter	Sub-Index	Meaning
915	3	Communication number for parameter transferred in PZD3
	4	Communication number for parameter transferred in PZD4
	5	Communication number for parameter transferred in PZD5
	6	Communication number for parameter transferred in PZD6
	7	Communication number for parameter transferred in PZD7
	8	Communication number for parameter transferred in PZD8
	9	Communication number for parameter transferred in PZD9
	10	Communication number for parameter transferred in PZD10

Assignment in PZD Read (Inverter to PLC)

Parameter	Sub-Index	Meaning
916	3	Communication number for parameter transferred in PZD3
	4	Communication number for parameter transferred in PZD4
	5	Communication number for parameter transferred in PZD5
	6	Communication number for parameter transferred in PZD6
	7	Communication number for parameter transferred in PZD7
	8	Communication number for parameter transferred in PZD8
	9	Communication number for parameter transferred in PZD9
	10	Communication number for parameter transferred in PZD10

The process data is configured through the profile specific array parameters 915 and 916. The data written to them will be stored in non-volatile memory, either in the inverter or in the on-board serial E2PROM memory. They might also be configured with the keypad of the inverter, but if that is the case a restart of the module is required.

When accessing array parameters, such as 915 and 916, the "IND" field is used to specify the array sub-index. Only the high byte of the "IND" word is used, the low byte is reserved (see 3-2 “PKW-Part”).

PZD Words 1 & 2

PZD words 1 and 2 cannot be configured, their meaning is always fixed according to the table below.

PZD	PROFIdrive Mode	VENDOR SPECIFIC Mode
PZD1	PROFIdrive Control-/Status word	Vendor Specific Control-/Status word
PZD2	PROFIdrive Reference-/Actual value	Vendor Specific Reference-/Actual value
PZD3-10	Freely configurable	Freely configurable

PKW-Part

The parameter area (PKW) is fixed to 4 words and can be used for reading and/or updating the parameters in the inverter one by one. Requests and responses is a handshake procedure and cannot be batched, meaning that if the master sends out a read/write request, it has to wait for the response, before it sends a new request.

The PKW area consists of three 4 words, see below.

- **PKE**
Parameter Characteristics. See 3-2 “PKE (PKW word 1) Explanation”.
- **IND**
Sub-index.
- **PWE**
Parameter value.

PKE (PKW word 1) Explanation

This word contains several subparts which are described below.

bit 15	bit 14	bit 13	bit 12	bit 11	bit 10	bit 9	bit 8	bit 7	bit 6	bit 5	bit 4	bit 3	bit 2	bit 1	bit 0
AK				SPM	PNU										

- **PNU (PNU bits 0...10)**
Parameter. See 4-1 “PROFIdrive Profile Specific Parameters” for the PROFIdrive specific parameters.
- **SPM (PKE bit 11)**
Spontaneous Message Bit Toggle bit for Spontaneous Messages.
- **AK (PKE bits 12...15)**
This field defines the request/response type that is issued. If the Request/Response contains array elements, the high byte (byte 3) of the IND word (See 3-2 “IND”) will carry the array sub index, low byte (byte 4) is reserved for future use.

Value	Function (Request)	Function (Response)
0	No request	No response
1	Request parameter value	Transfer parameter value (word)
2	Change parameter value (word)	Transfer parameter value (long word)
3	Change parameter value (long word)	Transfer description element ^a
4	Request description element ^a	Transfer parameter value (array word)
5	Change description element ^a	Transfer parameter value (array long word)
6	Request parameter value (array)	Request number of array elements
7	Change parameter value (array word)	Request rejected (including Fault Number, see 3-3 “Fault Number”)
8	Change parameter value (array long word)	Not parameter change rights by PKW interface
9	Request number of array elements	(not used)
10 - 15	(not used)	(not used)

a. Not supported

Fault Number

If the inverter rejects a request from the master, the AK word in the PPO-read will indicate this by assuming value 7 or 8. The describing Fault Number will be found in the PWE field.

Fault Number	Meaning
0	Illegal parameter number
1	Parameter value cannot be changed
2	Upper or lower limit violated
3	Erroneous sub-index
4	No array
5	Incorrect data type
6	Setting not allowed, can only be reset
7	Descriptive element cannot be changed
9	Descriptive data not available
11	No parameter change rights
15	Text array not available
17	Task cannot be executed due to operating status (e.g. parameter is currently read-only)
18	Other error
101	Vendor specific error
102	Request not supported
103	Request cannot be completed due to communication error
110	Failure during write to non-volatile memory
111	Request aborted due to time-out
120	Parameter cannot be mapped to PZD (size mismatch or non-existent)
121	Parameter cannot be mapped to PZD, out of memory
122	Parameter cannot be mapped to PZD, multiple PZD write
130	Cannot map Control word bit (parameter 933 - 937, e. g. double mapping of bits)
140	Cannot change mode to TORQUE (frequency is used)

PZD-Part

With the PZDs the user is able to configure what data that shall be cyclically transferred between the master and the slave (in this case the inverter). The number of PZDs to use depends on the selected PPO-type. All PPO's support at least two words of PZD.

The PZD area consists of a fixed part (all PPOs, PZD1 and PZD2) and a configurable part (PPO 2,4 & 5, PZD3-10). Using "Extended user parameter data" telegrams, the module can be configured to act either as "PROFIdrive" or "Vendor Specific" (see 2-2 "User Parameter Data" and the table below).

- **PROFIdrive**

In this mode, the contents of PZD1 and PZD2 are predefined according to PROFIdrive, and are used to transfer the current control word (STW) and speed reference (HSW) while the status word (ZSW) and the actual output frequency (HIW) are transferred from the inverter to the Profibus master.

- **Vendor Specific**

In this mode, the contents of PZD1 and PZD2 are vendor specific, i.e. they are transparent to the PROFIdrive profile. Please note that in this mode, the PROFIdrive Control and Status words are handled by the inverter itself.

For more information about how to configure the PZD words, see 2-5 "Configuration of PZD words".

Profile Mode and Vendor Specific Mode

(Please refer to 2-2 “User Parameter Data”)

PZD	PROFIdrive Mode	Vendor Specific Mode
PZD1	PROFIdrive Control-/Status word (See 3-4 “PROFIdrive Status Word” and 3-5 “PROFIdrive Control Word”)	Vendor Specific Control-/Status Word
PZD2	PROFIdrive Reference-/Actual value	Vendor Specific Reference-/Actual value
PZD3 ... PZD10	Freely configurable, see 2-5 “Configuration of PZD words”	Freely configurable, see 2-5 “Configuration of PZD words”

PROFIdrive Status Word

Note: This section is not relevant when running in Vendor Specific mode.

The status word indicates the status of the inverter (Inverter -> PLC).

Bit	Value	Meaning	Remark
0	1	Ready to switch-on	Control word bit 0=0 and bits 1, 2, 10 are set to 1 (“Ready to switch-on” state).
	0	Not ready to switch-on	Control word bit 0, 1 or 2 (OFF1, OFF2, OFF3) is set to 0, or the inverter is tripped.
1	1	Ready for operation	Control word bit 0, 1 and 2 are set to 1. Inverter is not faulted (Ready state).
	0	Not ready for operation	Control word bit 0, 1 or 2 (OFF1, OFF2, OFF3) is set to 0, or the inverter is faulted.
2	1	Operation enabled	Control word bit 0, 1, 2 and 3 are set to 1. Inverter is not faulted (Enable operation state).
	0	Operation inhibited	Control word bit 0, 1, 2 or 3 (OFF1, OFF2, OFF3, Operation disabled) is set to 0, or the inverter is faulted.
3	1	Fault	Inverter is faulted.
	0	No fault	Inverter is not tripped.
4	1	ON2	Control word bit1=1.
	0	OFF2	OFF2 command active. Control word bit1=0 (OFF2 active state).
5	1	ON3	Control word bit2=1.
	0	OFF3	OFF3 command active. Control word bit2=0 (OFF3 active state).
6	1	Start enable	Control word bit 1 or 2 (OFF2, OFF3) is set to 0 or fault has been acknowledged (Switch-on inhibit state).
	0	No switch-on inhibit	Control word bit 0=0 and bit10=1 (Not ready to switch-on state).
7	-	(reserved)	-
8	1	Frequency equal set-point	Actual output frequency does equal frequency set point.
	0	Frequency not equal set-point	Actual output frequency does not equal frequency set point (i.e. motor accelerating/decelerating).
9	1	Bus control	Run command or frequency setting is valid via Profibus.
	0	Local control	Run command and frequency setting are invalid via Profibus.
10	-	(reserved)	-
11 - 15	-	(Configured using profile specific parameters 933-943)	

PROFIdrive Control Word

Note: This section is not relevant when running in Vendor Specific mode.

The control word is used to send control commands to the inverter (PLC->Inverter).

Bit	Value	Meaning	Remark
0	1	ON1	Inverter can be started if all other start conditions are fulfilled. Enter "Ready" state, requires the state machine to be in "Ready to switch on" state.
	0	OFF1	Normal stop; uses deceleration time specified in Dec time 1.
1	1	ON2	Inverter can be started if all other start conditions are fulfilled.
	0	OFF2	Inverter coast to stop. Enter "Switch-on inhibit" state.
2	1	ON3	Inverter can be started if all other start conditions are fulfilled.
	0	OFF3	Quick stop that uses deceleration time specified in Dec time 2. Enter "Switch-on inhibit" state.
3	1	Operation enabled	Inverter can be started if all other start conditions are fulfilled. Enter "Enable Operation" state.
	0	Operation disabled	Inverter coast to stop. Enter "Inhibit operation state".
4	1	Condition for operation	Inverter can be started if all other start conditions are fulfilled. Enter "Ramp-function generator: Enabled output".
	0	Ramp generator disabled	Output of RFG is set to zero. Inverter decelerate along the current or voltage limit.
5	1	Ramp generator enabled	Inverter can be started if all other start conditions are fulfilled. Enter "Ramp function generator: Acceleration enabled".
	0	Stop ramp generator	Actual frequency set point from RFG is frozen.
6	1	Enable set-point	Inverter can be started if all other start conditions are fulfilled.
	0	Inhibit set-point	Reference frequency is set to zero.
7	1	Acknowledge	Fault is acknowledged on positive edge, i.e. bit 7=0 then 1 (Enter "Switch-on inhibited state").
	0	(no function)	-
8	1	Jogging1 ON	Inverter accelerates as fast as possible to Jogging set point 1. Inverter must be in "Enable Operation" state.
	0	Jogging 1 OFF	Inverter brakes as fast as possible along the current limit. Enters "Enable Operation".
9	1	Jogging2 ON	Inverter accelerates as fast as possible to Jogging set point 2. Inverter must be in "Enable Operation" state.
	0	Jogging2 OFF	Inverter brakes as fast as possible along the current limit. Enters "Enable Operation".
10	1	Data valid	The control word and frequency set point (from Profibus) are activated.
	0	Data invalid	The control word and frequency set point (from Profibus) are not valid.
11 - 15	1/0	Device related	The value of this bit can be configured so that its value is mirrored in one of the Vendor-specific bits in the control word transferred from AnyBus to inverter.

PROFIdrive State Machine

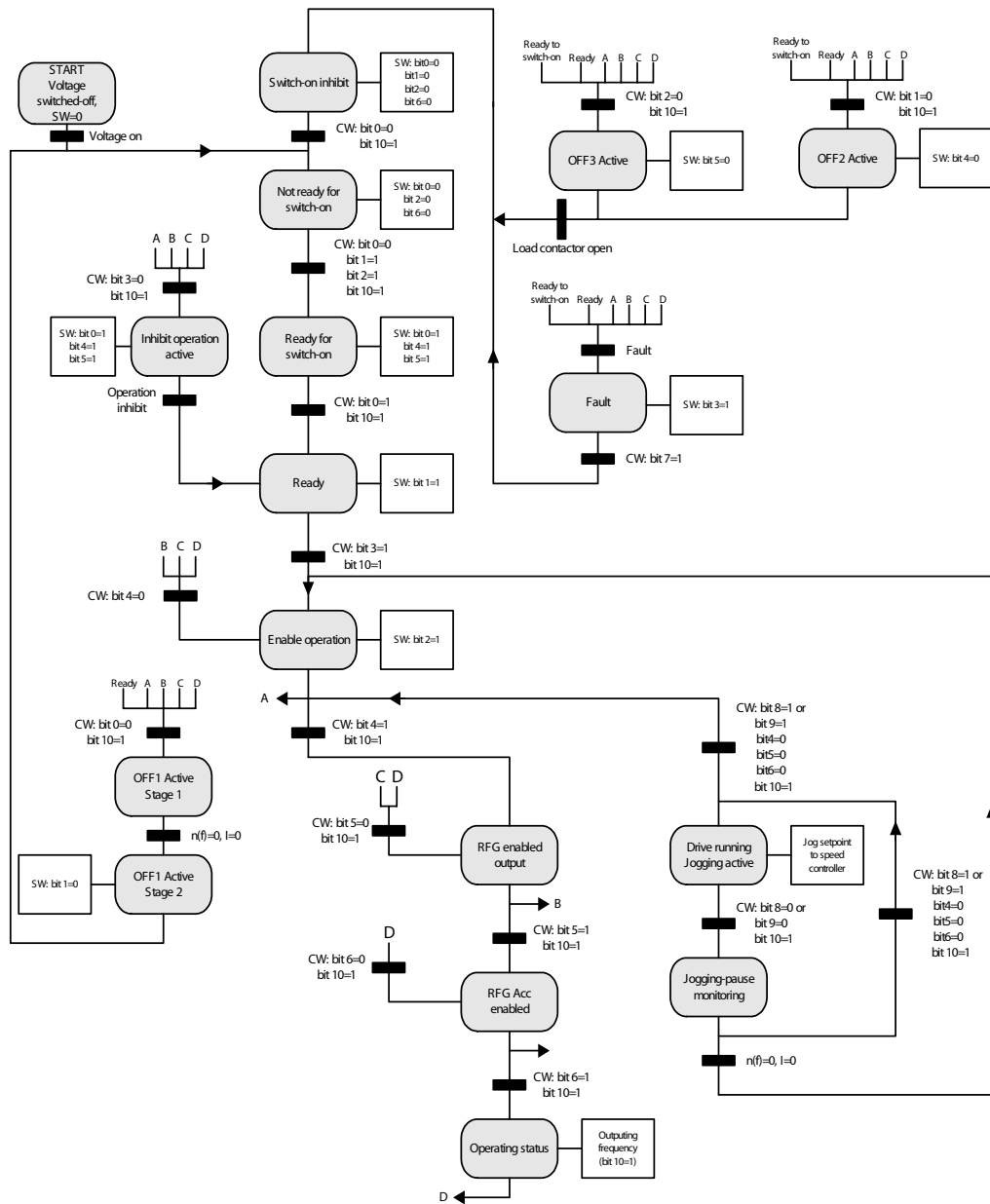

Set-point/Actual value

Depending on how parameter 930 (Selection switch for operation mode) these values have slightly different meaning. These values are in both cases scaled in the same way. The two possible settings available are:

- Speed control mode, frequency/speed - p 930 = 1h : The set-point and the actual value are given in relation to the Rated Frequency of the motor (Parameter #P18).
- Speed control mode, Torque - p 930 = 8001h : The set-point and the actual value are given in relation to the Rated Torque of the motor (Parameter #P20).

The data format is "Standardized value", where 0 hex = 0 % and 4000h represents 100% of the related value. A small example: Parameter 930 is set to one. The rated frequency of the motor is 75 Hz. If the actual value is 2000h this means that the motor is running at 50% of the rated frequency, that is, 37.5 Hz.

Standardized Value

A linear value; 0%=0 (0h), 100% is 2^{14} (4000h)

Data type: N2
 Range: $-200\% \dots 200\% \cdot 2^{14}$
 Resolution: $2^{14} = 0.0061\%$
 Length: 2 bytes
 Notation: 2's complement notation
 MSB is 1st bit after sign bit in 1st byte
 Sign bit = 0 = positive number
 Sign bit = 1 = negative number

	Bit 8	Bit 7	Bit 6	Bit 5	Bit 4	Bit 3	Bit 2	Bit 1
Byte 1	SIGN	2^0	2^{-1}	2^{-2}	2^{-3}	2^{-4}	2^{-5}	2^{-6}
Byte 2	2^{-7}	2^{-8}	2^{-9}	2^{-10}	2^{-11}	2^{-12}	2^{-13}	2^{-14}

Acyclic Parameter Channel (DPV1)

Characteristics of the acyclic parameter access:

- Several parameters can be transferred with one request, however, only one request can be transferred at one time.
- No cyclic requests (PKW)

A request is transferred from the master to the slave using an acyclic write request. The structure of such a request is described in the tables below.

DPV1 Request Header Structure

Request Header	Request Reference	Request ID
	Axis	No. of Parameters(n)
1 ST Parameter Address	Attribute	No. of Elements
	Parameter Number	
	Sub Index	
n TH Parameter Address	...	
1 ST Parameter Value(s) ^a	Format	No. of Values
	Values or Error Values	
	...	
n TH Parameter Values	...	

a. Only after request 'Modify'

DPV1 Response Header Structure

Request Header	Request Reference (Mirrored)	Response ID
	Axis (Mirrored)	No. of Parameters(n)
1 ST Parameter Value(s) ^a	Format	No. of Values
	Values or Error Values	
	...	
n TH Parameter Values	...	

a. Only after request 'Request'

DPV1 Request/Response Header Explanation

Field(s)	Description	Range
Request Header Response Header	Unique identification set by the master. Is changed for each new request. Mirrored in the response.	1 - 255
Request ID	Request type for the issued block	Request Parameter (01h) Change Parameter (02h)
Response ID	Response from the slave. In case any of the requested services fail, a NAK will be indicated.	Request Param OK (01h) Request Param NAK (81h) Change Param OK (02h) Change Param NAK (82h)
Axis	This field is not used by the module and should be set to zero.	0 - 255
No. of Parameters	The number of parameter requests/responses that are present in the request/response.	1 - 37
Attribute	Type of object being accessed. Note: 'Text' is not supported.	Value (10h) Description (20h) Text (30h)
Number of Elements	Number of array elements that are accessed or length of string which are accessed. Set to zero if non-array parameters are used.	0, 1 - 234
Parameter Number	Address of the parameter that is being accessed. Note that in 'Formula' mode, also 0 is allowed.	1 - 65535
Sub Index	Addresses the first array element of the parameter or the beginning of a string access or the text array, or the description element that is being accessed.	0 - 65535
Format	Different kind of data is supplied in this field, depending on the status of the response/request.	01h - 36h (Data Type), 40h (Zero) 41h (Byte) 42h (Word) 43h (Double Word) 44h (Error)
Number of Values	Number of values following	0 - 234
Values	The values of the request/response. In case of odd number of bytes, a zero bytes is appended to ensure the word structure of the telegram.	-

DPV1 Parameter Request Error Codes

Error #	Meaning	Used At
00h	Impermissible parameter number	Access to unavailable parameter
01h	Parameter value cannot be changed	Change access to a parameter value that cannot be changed
02h	Low or high limit exceeded	Change access with value outside the values limits
03h	Faulty subindex	Access to unavailable subindex
04h	No array	Access with subindex to non-indexed parameter
05h	Incorrect data type	Change access with value that does not match the data type of the parameter
06h	Setting not permitted (can only be reset)	Change access with value unequal to 0 where this is not permitted
07h	Description element cannot be changed	Change access to a description element that cannot be changed
09h	No description data available	Access to unavailable description (parameter value is available)
0Bh	No operation priority	Change access rights without rights to change parameters
0Fh	No text array available	Access to text array that is not available (parameter value is available)
11h	Request cannot be executed because of operating mode	Access is temporarily not possible for reasons that are not specified in detail
14h	Value impermissible	Change access with a value that is within the value limits but is not permissible for other long-term reasons (parameter with defined single values).
15h	Response too long	The length of the current response exceeds the maximum transmittable length.
16h	Parameter address impermissible	Illegal value or value which is not supported for the attribute, number of elements, parameter number or sub-index or a combination.
17h	Illegal format	Write request: Illegal format or format of the parameter data which is not supported.
18h	Number of values are not consistent	Write request: Number of values of the parameter data do not match the number of elements in the parameter address.
65h-FFh	Manufacturer specific	-
65h	Vendor specific error.	Vendor specific error.
66h	Request not supported	Request not supported.
67h	Communication error	Request cannot be completed due to communication error.
68h-6Dh	Manufacturer specific	-
6Eh	Non-volatile error	Failure during write to non-volatile memory.
6Fh	Time-out error	Request aborted due to time-out.
70h-77h	Manufacturer specific	-
78h	PZD map fail	Parameter cannot be mapped to PZD (size mismatch or non-existent).
79h	PZD memory failure	Parameter cannot be mapped to PZD, out of memory.
7Ah	Multiple PZD map	Parameter cannot be mapped to PZD, multiple PZD write.
7Bh-81h	Manufacturer specific	-
82h	Control word bit map	Cannot map Control word bit (parameter 933-937, e.g., double mapping of bits).
83h-8Bh	Manufacturer specific	-
8Ch	Set torque mode error	Cannot change mode to TORQUE (frequency is used).
90h	Illegal Request ID	The request ID of the response is illegal.
8Dh-FFh	Manufacturer specific	-

Parameters

PROFIdrive Profile Specific Parameters

#	Description	Data Type	R/W
915	Assignment PZD1-10 in PPO-write ^a	Array [10] UINT16	R/W
916	Assignment PZD1-10 in PPO-write ^a	Array [10] UINT16	R/W
918	Node address. Writing this parameter will write parameter BUS_CONFIG_1. This parameter is read once during startup, i.e. a restart of the module is required.	UINT16	R/W
919	Device system number (Set using Development Tool)	UINT32	R
927	Operator control rights (Parameter Identification/PKW) Value: Mode: 0 Parameters cannot be written, only read (parameter 927 can be written) 1 Parameters can be written and read (default)	UINT16	R/W
928	Control rights (Process Data/PZD) Value: Mode: 0 PZD part is disabled, that is PZD1-10. Write are ignored. 1 PZD is enabled (default).	UINT16	R/W
929	Selected PPO-type Value: PPO-type: Configuration: 1 PPO1 F3h, F1h 2 PPO2 F3h, F5h 3 PPO3 F1h 4 PPO4 F5h 5 PPO5 F3h, F9h 6 PPO6 F9h	UINT16	R
930	Selection switch for operation mode Value: Mode: 1 Speed control mode, frequency/speed HSW/HIW. 8001h Speed control mode, torque HSW/HIW	UINT16	R/W
933	Selection switch, Control Word, bit 11 ^b Value: Inverter Control Word bit: 0 No use 1 Vendor specific 1 2 Vendor specific 2 3 Vendor specific 3 4 Vendor specific 4 5 Vendor specific 5	UINT16	R/W
934	Selection switch, Control Word, bit 12 (coding is the same as for 933)	UINT16	R/W
935	Selection switch, Control Word, bit 13 (coding is the same as for 933)	UINT16	R/W
936	Selection switch, Control Word, bit 14 (coding is the same as for 933)	UINT16	R/W
937	Selection switch, Control Word, bit 15 (coding is the same as for 933)	UINT16	R/W
939	Selection switch, Status Word, bit 11 Value: Inverter Control Word bit: 0 No use 1 Vendor specific 1 2 Vendor specific 2 3 Vendor specific 3	UINT16	R/W
940	Selection switch, Status Word, bit 12 (coding is the same as for 939)	UINT16	R/W
941	Selection switch, Status Word, bit 13 (coding is the same as for 939)	UINT16	R/W
942	Selection switch, Status Word, bit 14 (coding is the same as for 939)	UINT16	R/W

#	Description	Data Type	R/W
943	Selection switch, Status Word, bit 15 (coding is the same as for 939).	UINT16	R/W
945	Fault code of fault n (coding is according to DriveCOM profile)	Array [64] UINT16	R
947	Fault number	Array [64] UINT16	R
948	Time difference. Seconds since the fault occurred.	Array [64] UINT16	R
952	Number of faults. The number of faults that has occurred until this moment. Writing zero will clear number of faults counter.	UINT16	R/W
953	Last alarm (meaning is vendor specific)	UINT16	R
954	Second latest alarm	UINT16	R
955	Third latest alarm	UINT16	R
956	Fourth latest alarm	UINT16	R
957	Fifth latest alarm	UINT16	R
958	Sixth latest alarm (not currently supported)	UINT16	R
959	Seventh latest alarm (not currently supported)	UINT16	R
960	Eighth latest alarm (not currently supported)	UINT16	R
961	Hardware configuration, manufacturer specific ID regarding the inverter hardware structure. Mapping of the parameter INVERTER_TYPE_CODE.	UINT32	R
963	Current baud rate Value: Baud rate: Value: Baud rate: 0 12 Mbit/s 5 187.5 kbit/s 1 6 Mbit/s 6 93.75 kbit/s 2 3 Mbit/s 7 45.45 kbit/s 3 1.5 Mbit/s 8 19.2 kbit/s 4 500 kbit/s 9 9.6 kbit/s	UINT16	R
964	Device Identification Sub Index: Explanation: Value: 0 Manufacturer HMS = 01C0h 1 Device Type 0102h = AnyBus-S Drive Profile DPV 2 Version XXYY decimal 3 Firmware Date Year, yyyy decimal 4 Firmware Date Day, month: ddm decimal 5 No. of axes 1 6 Device ID (Read from configuration file, HMS = 1801h)	UINT16	R
965	Profile number. Octet str: Profile number: Version number: 0302h 3 2	Octet String [2] (UINT16)	R
967	Control word (STW)	UINT16	R
968	Status word (ZSW)	UINT16	R
970	Load parameter record ^c Value: Description: 0 No description. 0 ->1 Factory reset of inverter.	UINT16	R/W
971	Transfer into non-volatile memory ^c Value: Description: 0 No description 0->1 Save the inverter parameters to non-volatile memory.	UINT16	R/W
972	Software reset ^c Value: Description: 0 No description 0 ->1 Re-boot AnyBus-S module.	UINT16	R/W

a. Note - Only sub-index 3-10 are supported

b. Please note that it is not possible to assign several different Control Word bits to the same Vendor Specific bit.

c. Please note that the parameter needs to do a zero-to-one transition and the motor must be stopped.

Description Elements

Description elements will only be supported in the acyclic DPV1 mode. Description elements are available for all PROFIdrive specific (p.900-999) parameters, however, to be able to read out complete description elements for vendor specific parameters the user will have to add one description object for each PROFIdrive parameter number. Note that description elements are not accessible on “SubIndex” level. It will **not** be possible to change the description elements.

In case the configuration file contains no description elements the module will attempt to generate as much information as possible. However, not all information can be generated.

Parameter Description Overview

Sub Index	Meaning	Data Type	Note
1	Identifier (ID)	V2 (bit field)	See 4-4 “Identifier (ID)”
2	Number of array elements or length of string	Unsigned 16	Configured with ABSDP Development Tool.
3	Standardization factor	Floating Point (4byte)	Configured with ABSDP Development Tool.
4	Variable attribute	Octet String 2	Configured with ABSDP Development Tool.
5	(reserved)	Octet String 4	-
6	Name	Visible String 16	Configured with ABSDP Development Tool.
7	Low limit	Octet String 4	Configured with ABSDP Development Tool.
8	High limit	Octet String 4	Configured with ABSDP Development Tool.
9	Reserved	Octet String 2	-
10	ID extension	V2	Reserved for future use.
11	PZD reference parameter	Unsigned 16	Not supported (0).
12	PZD normalization	V2	Not supported (0).
0	Complete description	Octet String 46	

If no description array is available for a requested parameter (or not at all) the following description will still be available (not available in “FORMULA” mode):

Sub Index	Meaning	Data Type	Note
1	Identifier (ID)	V2 (bit field)	See 4-4 “Identifier (ID)”
2	Number of array elements or length of string	Unsigned 16	Depends on the selected parameter access method: Specific – Calculated. Linear – 0.
3	Standardization factor	Floating Point (4byte)	0
4	Variable attribute	Octet String 2	0
5	(reserved)	Octet String 4	0
6	Name	Visible String 16	Returns a string containing the parameter that is requested. E.g., “Parameter 2202”.
7	Low limit	Octet String 4	0
8	High limit	Octet String 4	0
9	(reserved)	Octet String 2	0
10	ID extension	V2	0
11	PZD reference parameter	Unsigned 16	0
12	PZD normalization	V2	0

Identifier (ID)

The Identifier field describes the properties of the parameter.

Bit	Meaning	Value	Note
15	(reserved)	-	-
14	Array	0	Not array parameter.
		1	Parameter is of array type.
13	Value can only be reset	0	Parameter is writeable.
		1	Parameter can only be reset (that is, it is only possible to write "0" to the parameter).
12	Parameter is changed with respect to factory setting	-	Not supported.
11	(reserved)	-	-
10	Additional text array available	-	Not supported.
9	Parameter not writeable	0	Parameter can be written.
		1	Parameter read-only.

In case the configuration doesn't contain any valid description array for a parameter the following information is generated (please note that description elements can only be generated for parameters that are present in the VSO array):

Bit	Meaning	Note
15	(reserved)	0
14	Array	Depends on the selected parameter access method: Specific – Generated. Linear – 0.
13	Value can only be reset	0
12	Parameter is changed with respect to factory setting	0
11	(reserved)	0
10	Additional text array available	0
9	Parameter not writeable	Depends on the VSO configuration.
8	Standardization factor and variable attribute not relevant	1
0-7	Data type of the parameter value	Depends on the VSO configuration.

Fault Buffer Explanation

This implementation of the PROFIdrive profile supports up to five different faults. The fault codes of the faults can be accessed by using PROFIdrive parameters 945, 947 and 948. These three parameters are all of array type with 64 indexes, ranging from 1 to 64. All these parameters are in one way connected to each other, that is: p. 945 with sub-index 1 corresponds to p. 947 and p. 948 with sub-index 1.

Parameter 945: Contains the number of the fault. Zero indicates no fault.

Parameter 947: Contains the fault code of the fault. The fault code is coded as described in Interbus DRIVECOM specification (Chapter 3.7). Zero indicates no fault.

Parameter 948: Contains the Time since the fault occurred.

No Fault is Unacknowledged

Sub-Index	945 Fault Code	947 Fault Number	948 Time Difference	Note
0	0	0	0	Current fault (not acknowledged)
8	-	1	-	Last acknowledged fault
16	-	2	-	2nd latest acknowledged fault
24	-	3	-	3rd latest acknowledged fault
32	-	4	-	4th latest acknowledged fault
40	-	5	-	5th latest acknowledged fault
Other indexes	0	0	0	Always unused

1 Fault is Unacknowledged

Sub-Index	945 Fault Code	947 Fault Number	948 Time Difference	Note
0	-	1	-	Current fault (not acknowledged)
8	-	2	-	Last acknowledged fault
16		3		2nd latest acknowledged fault
24		4		3rd latest acknowledged fault
32		5		4th latest acknowledged fault
40	0	0	0	Unused
Other indexes	0	0	0	Always unused

Bus Config Parameters

A parameter group with fieldbus specific configuration parameters are stored in the inverter, if the inverter supports it. The parameters are used to configure the behaviour of the Profibus module. If inverter does not support these parameters they will be stored in the serial EPROM memory on-board the Anybus. The inverter does not need to support all these parameters, but it is strongly recommended to support as many as possible. The behaviour of the Bus Config parameters may vary slightly depending on other configuration options (see notes below). Please note that only flexibility for the user is lost if not all Bus Config parameters are supported. The functionality can always be realized without support for these parameters.

Parameter	Name ^a	Settings	Default	R/W
BUS_CFG_1	Node address ^b	0 - 126	3	R/W
BUS_CFG_2	Baud rate	Value is given in kbit/s, chopped: Value: Baud rate: Value: Baud Rate 12000 12 Mbit/s 187 187.5 kbit/s 6000 6 Mbit/s 93 93.75 kbit/s 3000 3 Mbit/s 45 45.45 kbit/s 1500 1.5 Mbit/s 19 19.2 kbit/s 500 500 kbit/s 9 9.6 kbit/s	1500	R ^c
BUS_CFG_3	PPO-type	1 - 5	1	R ^c
BUS_CFG_4	PZD3 OUT ^d	0 - 65536	0	R/W
BUS_CFG_5	PZD3 IN ^d	0 - 65536	0	R/W
BUS_CFG_6	PZD4 OUT ^d	0 - 65536	0	R/W
BUS_CFG_7	PZD4 IN ^d	0 - 65536	0	R/W
BUS_CFG_8	PZD5 OUT ^d	0 - 65536	0	R/W
BUS_CFG_9	PZD5 IN ^d	0 - 65536	0	R/W
BUS_CFG_10	PZD6 OUT ^d	0 - 65536	0	R/W
BUS_CFG_11	PZD6 IN ^d	0 - 65536	0	R/W
BUS_CFG_12	PZD7 OUT ^d	0 - 65536	0	R/W
BUS_CFG_13	PZD7 IN ^d	0 - 65536	0	R/W
BUS_CFG_14	PZD8 OUT ^d	0 - 65536	0	R/W
BUS_CFG_15	PZD8 IN ^d	0 - 65536	0	R/W
BUS_CFG_16	PZD9 OUT ^d	0 - 65536	0	R/W
BUS_CFG_17	PZD9 IN ^d	0 - 65536	0	R/W
BUS_CFG_18	PZD10 OUT ^d	0 - 65536	0	R/W
BUS_CFG_19	PZD10 IN ^d	0 - 65536	0	R/W
BUS_CFG_20	DP comp mode	0 = DPV1 1 = DPV0	0	R/W

- The names specified in this column are the ones transferred in the ABS_INFO_TEXT message
- See 1-3 "Node Address Switches" for more information on how to determine the source of the node address.
- The parameter is read/only from the keypad, but can be written from the fieldbus
- PZD3-10 IN and OUT are used to configure the cyclic data exchange that is taken place on the Profibus. For more information about the PZD parameters, and how to configure them see 2-5 "Configuration of PZD words". The inverter does not need to support these parameters, but if it does support them (and lets the user change their values) the AnyBus module needs to be restarted in order for the change to be effective. When using PROFIdrive parameters 915/916 to change these values the changes are done immediately, no restart is necessary.

Configuration with the ABSDP Development Tool

With the Development Tool there are two different configurations that are related to the Profibus module:

- **PROFIdrive Specific Configuraiton**
- **Parameter Data Mapping**

Parameter mapping setup makes it possible to determine how the vendor specific objects that might be present in the configuration shall be accessed via the PKW channel of the PROFIdrive channel.

PROFIdrive Specific Configuration

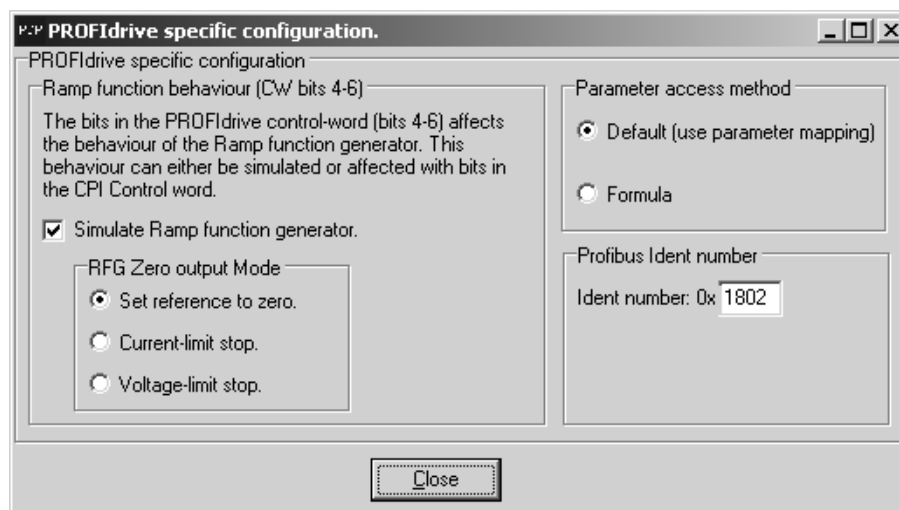

PNU Range	Sub-Index Range
RFG Zero Mode	Determines the action taken by the module when there is a request from the master/PLC to set the ramp function generator output to zero.
Profibus Ident number	The Profibus Ident number that the module shall use. Please note that this Ident number must match the one that is present in the GSD file. See also chapter .
Parameter access method	Choice of method to access parameters to use.
Simulate Ramp function generator	If activated the Reference Value to the application will follow the functionality indicated by bit 4, 5 and 6 in the PROFIdrive Control Word. If deactivated the Reference Value is transferred as it is without being influenced by bit 4., 5 and 6. In this case it is absolutely necessary that the application reads bit 6, 7 and 8 in the AnyBus Control Word.

Changing Profibus Ident Number

With the ABSDP Development Tool it is also possible to configure the Profibus Ident Number. The default value is the HMS Ident Number “0x1802”.

If a new Ident Number is desired, this has to be applied for at PNO (the Profibus User Organization). The GSD-file also needs to be changed with the new Ident Number.

The Ident Number can be changed in the Development Tool under “Profibus Specific Configuration”.

Parameter Data Mapping

To guarantee flexibility for accessing VSO parameters via the PROFIDrive PKW interface three different methods for determining how this shall be done is available:

- **User specific mapping**

By using the “PROFIDrive Parameter mapping” in the Development Tool, it is possible to map vendor specific parameters to a Profibus Parameter number. Vendor specific parameters have to be configured generally in the project (under Drive Setup) as to enable the Profibus specific mapping utility. The configuration is done with the ABSDP Development Tool and is unique for Profibus. Please note that a parameter can only be mapped as either array or no array. That is, parameter four cannot be mapped as both array and ordinary parameter. Also refer to chapter for more information. Requirements: “Parameter access method” = Default. Do not forget to conduct the mapping setup.

PNU Range	Sub-Index Range
1 - 899, 1000 - 2048	0 - 255

- **Linear mapping (no specific mapping available)**

The parameters of the vendor specific object configuration are mapped linearly on the PROFIDrive parameter protocol, that is, PNU 1 via PROFIDrive corresponds to the parameter that is placed first in the array of Vendor Specific objects. If no vendor specific objects are present no parameter access will be available (except for PROFIDrive specific parameters). Requirements: “Parameter access method” = Default. No mappings may be made with the mapping setup.

PNU Range	Sub-Index Range
1 - 899, 1000 - 2048	-

- **Formula mapping**

The parameters are configured using a formula to calculate the application parameter number. Please note that all vendor specific objects are mapped as array parameters with parameter number and sub-index. Size of the parameters are determined by the request type, that is, for "Change parameter value (word)" 2 byte parameters are assumed and for "Change parameter value (double word)" four bytes are assumed. When reading parameters the software tries to determine the size of the parameter by searching the array with Vendor specific objects (VSO). If not present in the VSO array 2 bytes are assumed. Requirements: “Parameter access method” = Formula.

PNU Range	Sub-Index Range
0 - 255	0 - 255

ApplicationNumber = [High byte = PNU] + [Low byte = sub-index].

Example: PNU=22 (16h). Sub-index=01. => ApplicationNumber 1601h (5633dec).

Example: PNU=99 (63h). Sub-index=09. => ApplicationNumber 6309h (25353dec).

Please note, that in all these three cases parameter range 900-999 are reserved for PROFIDrive profile and cannot be used for accessing vendor specific parameters.

User Specific Mapping Example

In this window all mappings that are done is shown. New additions are made with "Add parameter..." button. Furthermore, mappings made can be removed or updated (changed) with "Remove parameter..." and "Update parameter..." buttons. When all parameter mappings are completed the window is closed with the "Close" button.

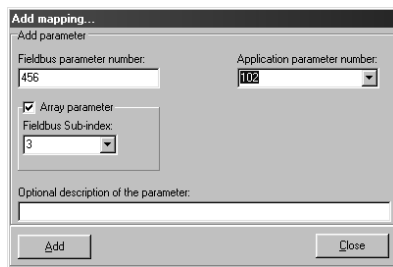

Adding a mapping

In the example above vendor specific parameter 102 is mapped to Profibus array parameter 456 with sub-index 3.

In the "Application parameter number" drop-down box all VSOs that has been added to the system is present. Please note that if no VSOs have been added it will not possible to do any mappings.

Example with two mappings made

In this example above we can see that two mappings are made: with the first one it is possible to access parameter 100 in the inverter/drive with Profibus parameter 123, with the second mapping parameter 101 is accessed with Profibus array parameter 456 with sub-index 2.



Profibus GSD file Generator

The configuration ABSDP Development Tool can automatically generate a GSD-file based on the configuration. To do this, select the TBD in the TBD menu.

The Profibus GSD file Generator window contains three tabs, 'Device Information', 'Company Information' and 'Preview'.

Device Information

This tab contains the settings for the Device Identification header in the GSD-file.

The tab also contains a checkbox used to select the type of GSD-file that should be generated, see below.

- GSD-file is for ABSDP-DPV1
(Checked = DPV1 mode, Unchecked = DPV0 mode)

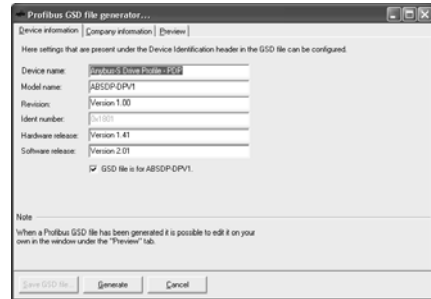

General Company Information

This tab contains general company information such as vendor name, address, phone, web etc.

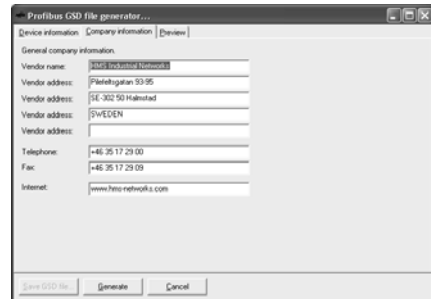

Preview

This tab displays a preview of the GSD-file. This tab is displayed automatically when clicking the 'Generate' button.

To save the finished GSD-file, click 'Save GSD file...'

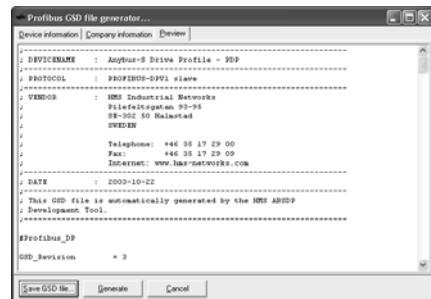

Connector Pinouts

Application Connector

This connector features a standard AnyBus-S Drive Profile application interface. Consult the general Anybus-S Drive Profile Design Guide for further information.

Fieldbus Connector

Female 9-pin D-sub (Recommended)

Pin	Signal	Description
Housing	Shield	Bus cable shield, connected to PE
3	B-Line	Positive RxD/TxD according to RS-485 specification
4	RTS	Request To Send ^a
5	GND BUS	Isolated GND from RS-485 side ^a
6	+5V BUS	Isolated +5V from RS-485 side ^a
8	A-Line	Negative RxD/TxD according to RS-485 specification
1, 2, 7, 9	-	-

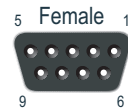

Screw terminal / Pluggable Screw Terminal

Pin	Signal	Description
1	+5V BUS	Isolated +5V from RS-485 side ^a
2	GND BUS	Isolated GND from RS-485 side ^a
3	A-Line	Negative RxD/TxD according to RS-485 specification
4	B-Line	Positive RxD/TxD according to RS-485 specification
5	Shield	Bus cable shield, connected to PE
6	RTS	Request To Send*

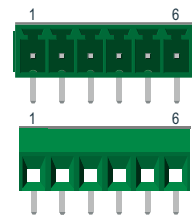

2mm Board to Board connector

Pin	Signal	Description
1	Shield	Bus cable shield, connected to PE
2	GND BUS	Isolated GND from RS-485 side ^a
3	RTS	Request To Send ^a
5	A-Line	Negative RxD/TxD according to RS-485 specification
6	B-Line	Positive RxD/TxD according to RS-485 specification
8	+5V BUS	Isolated +5V from RS-485 side ^a
4, 7, 9, 10	-	-



a. +5V BUS and GND BUS are used for bus termination. Some devices, like optical transceivers (RS485 to fibre optics) might require external power supply from these pins. RTS is used in some equipment to determine the direction of transmission. In normal applications only A-Line, B-Line and Shield are used.

Mechanical Specification

Angled Switches & Connectors (Standard)

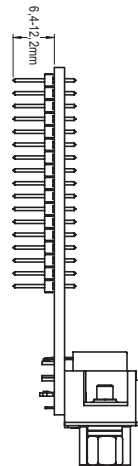
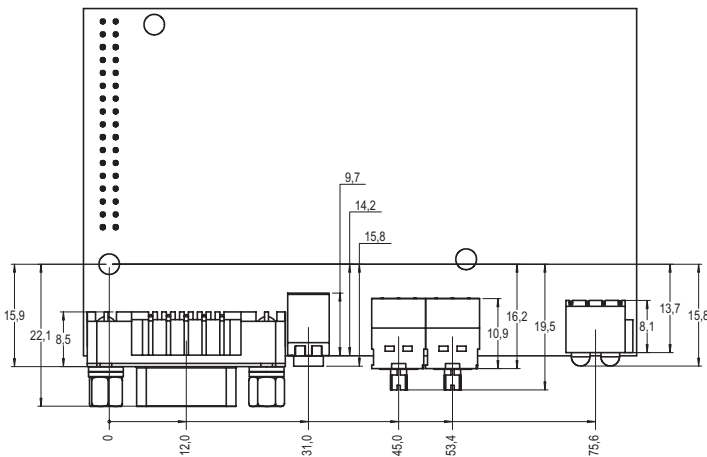
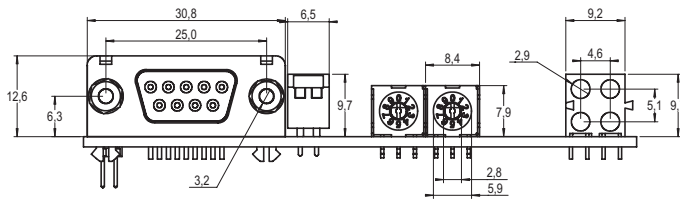
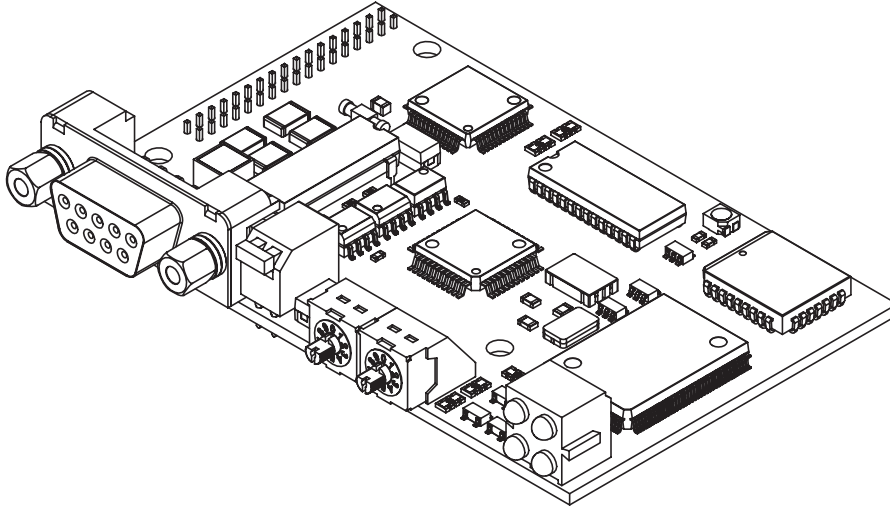

Straight Switches & Connectors

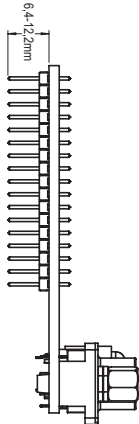
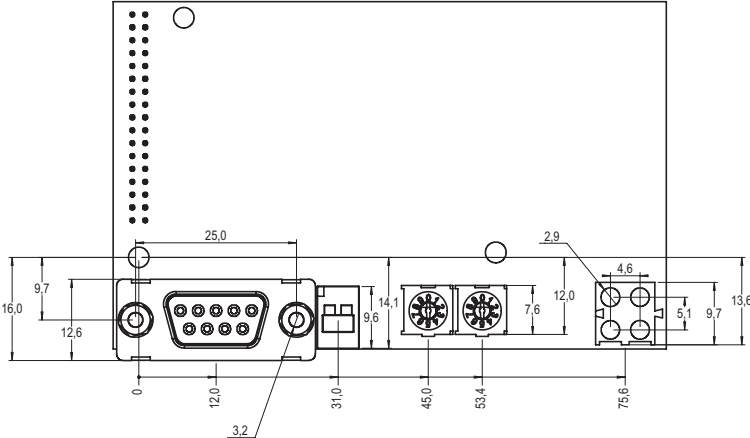
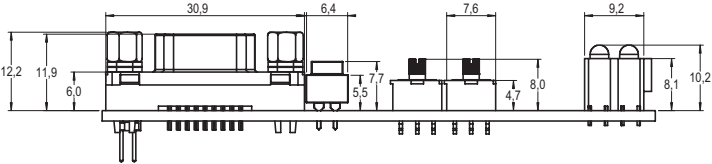
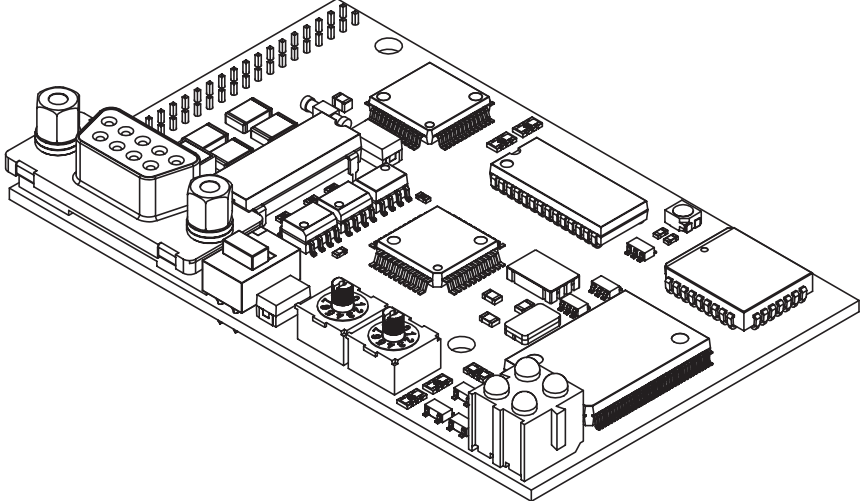

Electrical Characteristics

Supply Voltage

Both the module electronics and the fieldbus interface requires a regulated 5V DC power supply. For more information regarding power requirements, consult the AnyBus-S Drive Profile Design Guide.

Power Consumption

The maximum power consumption is 100mA on the bus interface. The total maximum power consumption from the application side is 350mA.

PE Grounding

A PE-connection is included on one of the mounting holes according to the AnyBus-S specification.

Environmental Specification

Temperature

Operating

+0 to +70 degrees Celsius

Test performed according to IEC-68-2-1 and IEC 68-2-2.

Non Operating

-15 to +85 degrees Celsius

Test performed according to IEC-68-2-1 and IEC 68-2-2.

Relative Humidity

The product is designed for a relative humidity of 5 to 95% non-condensing.

Test performed according to IEC 68-2-30.

EMC compliance

Emission

According to EN 61000-6-4:2001

Tested per 55011:1998, class A, radiated

Immunity

According to EN 61000-6-2:2001

Tested per EN 61000-4-2:1995

EN 61000-4-3:1996

EN 61000-4-4:1995

EN 61000-4-5:1995

EN 61000-4-6:1996

